

2. Description of the machine

The unit described in this manual is a form finisher for pressing wet shirts. This shirt finisher is designed for:

- Garment manufacturing industries;
- Large and small Industrial dry cleaners;
- Garment finishing industries.

The shirt finisher must be utilized by only qualified personnel, who have been specifically trained on this type of machinery.

The manufacturer does not accept any responsibility for damage caused to persons or things due to improper, erroneous or unreasonable utilization of the machine.

2.1. How to identify the machine

The machine is identified by a technical data plate. The plate is found on the back of the machine, as shown in Figure 2.1. Do not alter or modify in any way the data on the identification plate. Do not remove the identification plate.

Description of the data in the identification plate

Serial N	5 digits serial number
Type	Product code
V	Tension
Hz	Frequency (cycles)
kW	Power absorption
Date	Date of production

2.2. Technical specifications

Refer to Table 2.3 for technical specifications.

Figure 2.1 shows the dimensions of the machine.

i This manual describes all the versions of the machine. Before reading the manual identify the version of the machine you own by reading the machine "type" in the technical data plate. While reading the manual take into account only the information related to the version of machine you own.

Figure 2.1 - Identification plate

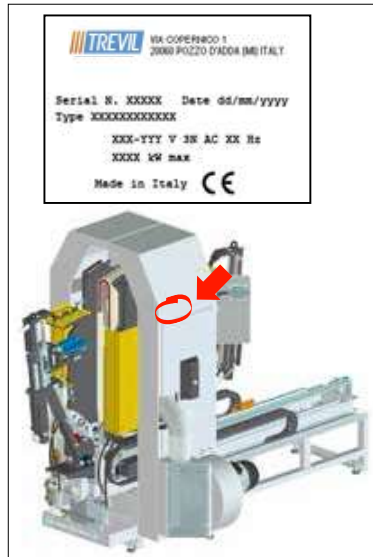

Figure 2.2 - Machine dimensions

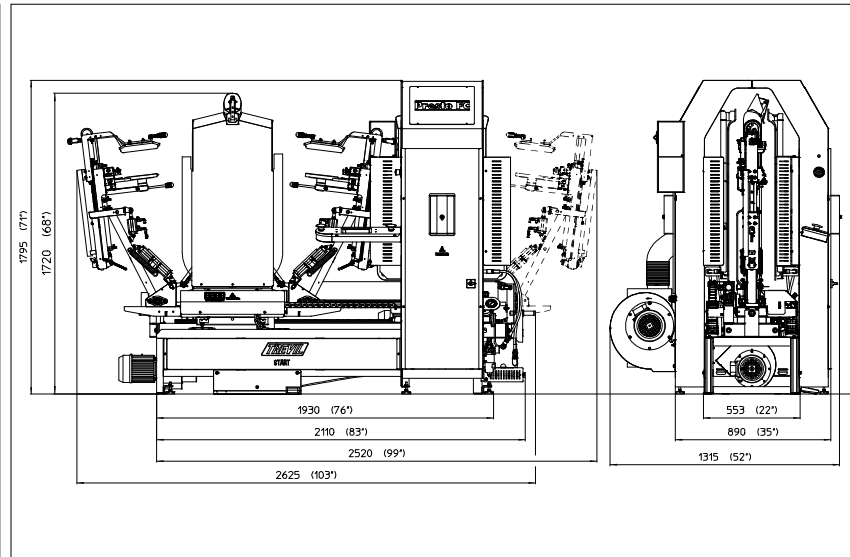

Table 2.3 - Technical specifications

	527x	527xT226T
Electrical requirements	400V 3N 50Hz	220V 3 60Hz
Steam inlet	G 3/4"	G 3/4"
Condensate return	G 3/4"	G 3/4"
Air inlet	G 1/2"	G 1/2"
Blowing motor	2,25 kW	3 HP
Suction motor	0,55 kW	0,75 HP
Steam pressure	500 - 800 kPa	72 - 116 PSI
Air pressure	500 kPa	72 PSI
Steam consumption	30 kg/h	66 lbs/h
Air consumption	50 NI/cycle	1,76 cfm
Net/Gross Weight	684 Kg	1507 lbs
Noise	80 dB	80 dB
Ambient temperature	15 to 40 °C	59 to 104 °C