

Barrier washer extractors

WS4/WSB4250H, WS4/WSB4350H,
WS4/WSB4500H, WS4/WSB4650H

Features and benefits

- Suitable for hygienic or clean room installations
- Suspended construction – no special foundation required
- Clarus Control microprocessor with nine fixed wash programs and up to 192 programs, free programming
- 5 compartment soap box for manual supply or connection to automatic liquid system
- Frequency controlled motor for variable drum speeds
- Interference filters and armoured cables for optimum safety and reliability
- Electric, gas, steam or thermal fluid heating

Main options

- Integrated load cells showing the weight in the display
- Stainless steel panels
- Clean room application
- Indirect steam heating



Main specifications			250	350	500	650								
Max. capacity		kg/lb	25/55	35/77	50/110	65/143								
Drum	volume	litre	250	350	500	650								
Drum	diameter	ø mm	770	770	770	770								
Extraction		rpm	910	910	910	910								
G-factor			350	350	350	350								
Heating alternatives	electricity	kW	18	27	36	54								
	steam		x	x	x	x								
	gas	Btu/h	83600	83600	136500	136500								
Consumption data "Normal 60°C" with pre-wash*														
			El	Steam	Gas	El	Steam	Gas	El	Steam	Gas			
Water consumption (cold)	litre		340	340	360	470	470	495	610	610	638	977	977	1005
Energy consumption (motor/heating)*	kWh		6	0.6	0.8	9.2	1	1.2	13.4	1.2	1.4	23	2	2.16
Steam consumption	kg		-	12	-	-	18	-	-	24.5	-	-	36	-

* Water temperature 15°C cold water.

Certified in accordance with ISO 9001 and ISO 14001 and approved IP 24D.

Electrical connections*			250	350	500	650
Heating Voltage						
EI.	400-415V 3 AC 50 Hz	kW(A)	21.7 (40)	32 (40)	42 (80)	61.5 (100)
	Steam 400-415V 3 AC 50 Hz or gas	kW(A)	3.7 (10)	4.8 (10)	5.8 (16)	7.8 (16)
Water, steam, gas and air connections						
Water valves	DN		20	20	20	20
Water pressure	kPa		50-300	50-300	50-300	50-300
Capacity at 250 kPa	l/min		70	70	70	70
Drain valve	ø mm		75	75	75	75
Draining capacity	l/min		133	133	133	133
Steam valve	DN		20	20	20	20
Steam pressure	kPa		300-600	300-600	300-600	300-600
Gas valve	DN		20	20	20	20
Gas evacuation	ø mm		125	125	125	125
Floor requirements						
Frequency of the dynamic force	Hz		0.767	0.767	0.767	0.767
Max transmitted floor load	daN		935	1164	1547	2055
Sound levels						
Airborne sound level	dB(A)		73	73	73	73
Heat emission						
% of installed power, max			5	5	5	5
Shipping data						
	net, kg		670	760	840	940
Dimensions in mm						
A	Width		1045	1285	1565	2000
B	Depth		980	980	980	980
C	Height		1610	1610	1610	1610
D			870	870	870	870
E			100	100	100	100
F			540	540	540	540
1	Electrical connection	7	Liquid supply connection			
2	Cold water	8	Soap box			
3	Hot water	9	Door opening			
4	Cold soft water	10	Control panel			
5	Steam connection	11	Gas evacuation			
6	Drain					

* Other voltages available, see installation manual.

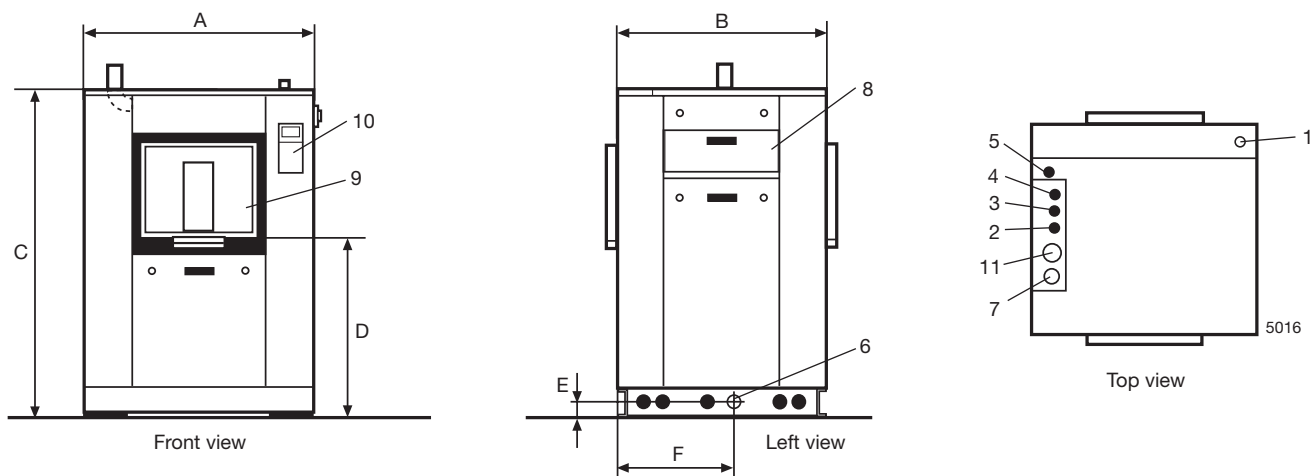

Electrolux

www.electrolux.com/professional

Share more of our thinking at www.electrolux.com

Art. No. 43890321/01 07.04
We reserve the right to alter specifications without notice.