

Washer extractor

W4400H

Features and benefits

- High extraction force for efficient dewatering
- Clarus Control® fully programmable, microprocessor with up to 192 programs
- Large door opening for easy loading/unloading
- Low noise level, for pleasant working environment
- One frequency controlled motor
- Prepared for 9 liquid detergent signals
- Eight liquid supply connections
- Stainless and galvanized steel in all vital parts for high degree of rust protection
- Stainless steel front panels and powder painted side panels
- Electrical or direct steam heating
- SuperBalance™ guarantees the correct extraction force

Main options

- Front-mounted loading hopper (manual)
- Forward tilting
- Backward and forward tilting
- Noise/heat insulation, <70 dB(A)
- Test tap with level tube
- Dual drain valves for water/solvent recovery
- Five-compartment supply injector
- Third water valve
- Integrated Weighing System™ (IWS)
- Oil lubrication of bearing gaskets



Main specifications				W4400H	
Max. capacity		kg/lb	45/100		
Drum, volume		litre	400		
	diameter	ø mm	920		
Extraction		rpm	825		
G-factor			350		
Heating alternatives		electricity	36		
		steam	x		
		hot water	x		
Consumption data "Normal 60°C" *				Electric heated	Steam heated
Total time		min	47	41	
Water consumption (cold/hot)		litre	482/81	563/-	
Energy consumption (motor/heating)		kWh	1.1/4.1	1.1/-	
Steam consumption		kg	-	12	

* Water temperature 15°C cold water and 65°C hot water.

Certified in accordance with ISO 9001 and ISO 14001 and approved IP 24D.

Electrical connections*		W4400H
Heating	Voltage	
El.	400-415V 3N AC 50 Hz	kW(A) 36(63)
Steam or non-heated	400-415V 3N AC 50 Hz	kW(A) 5.5(10)
Water, steam and air connection		
Water valves	DN	32
Rec. water pressure	kPa	150-400
Functioning limits for water valve	kPa	50-1000
Capacity at 300 kPa	l/min	150
Drain valve	Ømm	110
Draining capacity	l/min	400
Steam valve	DN	20
Rec. steam pressure	kPa	300-600
Functioning limits for steam valve	kPa	50-800
Compressed air	DN	6
Air pressure	kPa	200-400
Air consumption	l/h	20
Liquid detergent	DN	15
Floor requirements		
Frequency of the dynamic force	Hz	13.8
Max floor load at extraction	kN	13.0±0.75
Sound levels		
Sound level	dB(A)	75
Sound level with insulation	dB(A)	<70
Heat emission		
% of installed power, max		5
Shipping data		
	net, kg	1200
	crated, kg	1300
	boxed, kg	1450
Shipping volume	m ³	5.33

* Other voltages available, see installation manual.

Dimensions in mm

A	Width	1325
B	Depth	1450
C	Height std feet	2015
C	Height low feet	1890
D		910
E		300
F		1865
G		270
H		820
I		420
K		435
L		425
M		525
N		660
O		2235
P		950
R		830
S		370
T		2205
U		1140
V		345

- 1 Control panel
- 2 Door opening \varnothing 535
- 3 Soap supply injector, powder (optional)
- 4 Cold water
- 5 Hot water
- 6 Water connection (optional)
- 7 Steam connection
- 8 Drain
- 9 Electrical power
- 10 Compressed air connection
- 11 External liquid supply 6 pcs \varnothing 10, 1 pc \varnothing 16 and 1 pc \varnothing 20
- 12 Water connector, soap supply injector (optional)

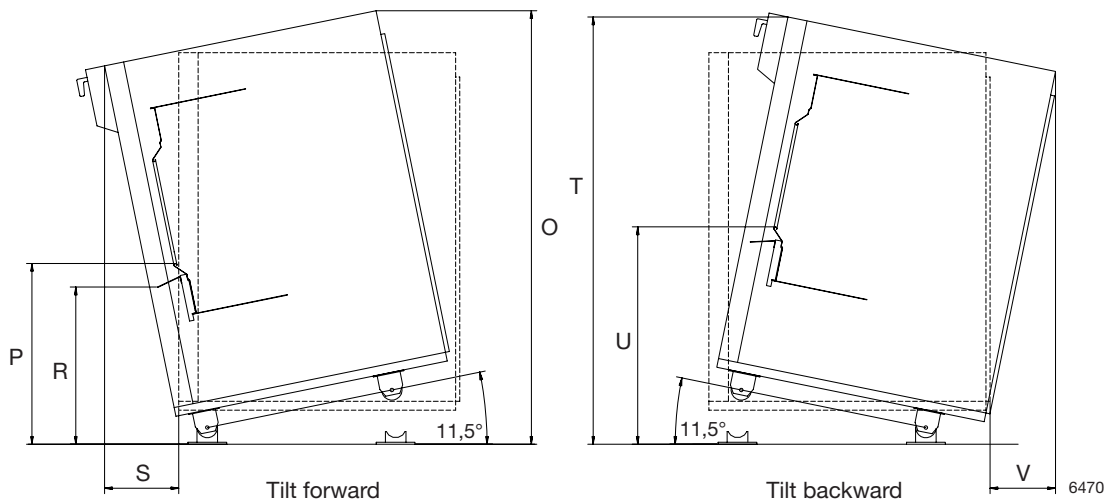
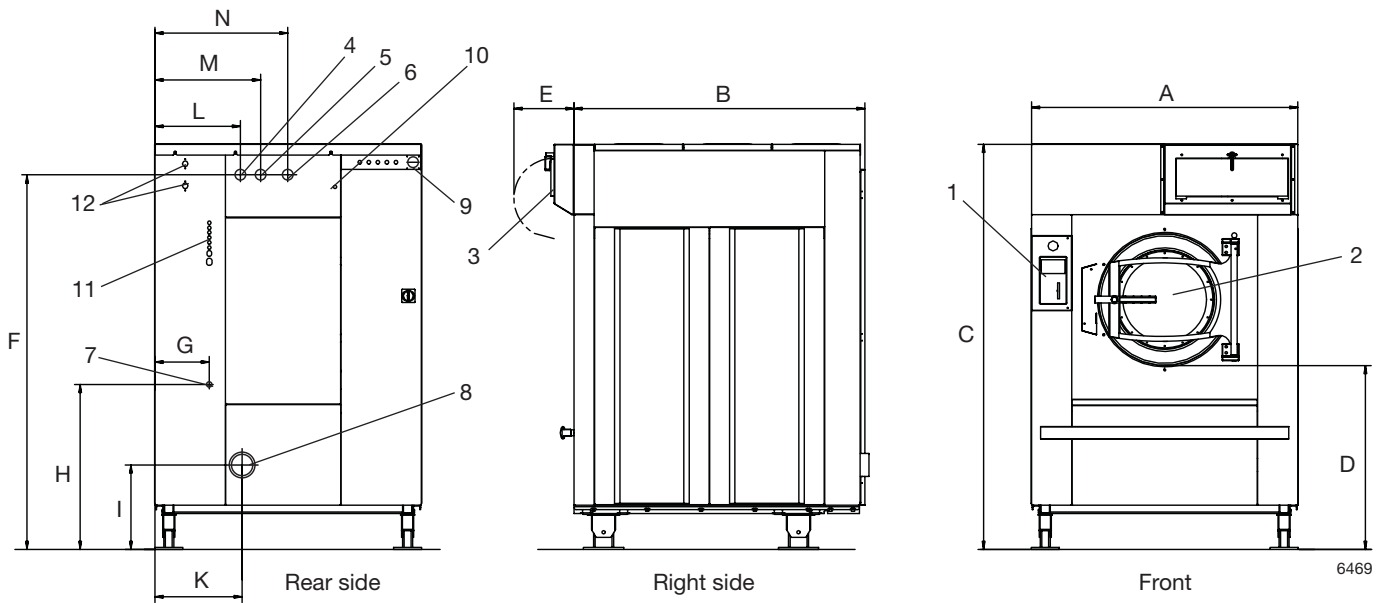

6469

6470

Options

- Front-mounted hopper - for easy loading from e.g sling-bag system (manual).
- Backward and forward tilting device - backward tilting can be used together with hopper or another type of loading system.
- Forward tilting device - for easy unloading with reversing drum into trolley.
- Noise/heat insulation - gives less airborne sound than 70 dB(A).
- Test tap with level tube - gives possibilities to take samples from the wash liquid.
- Water/solvent recovery drain- two drain valves to be able to recover water from the rinses and reuse it in the wash.
- Five-compartment supply injector, five-compartments for powder detergent which can be programmed.
- Water inlet via pump-extra water inlet for water supply controlled by a pump from a recovery system.
- Third water valve-electrically controlled water valve for e.g hard water.
- Connection details for steam.
- Connection details for 2 water.
- Connection details for 3 water.
- Connection details pump inlet.
- Integrated Weighing System (IWS) – shows the weight of the load on the program display.
- Combined steam and electrical heated - gives possibilities to choose between electrical or steam heating by using a switch.
- Oil lubrication of bearing gaskets with warning for empty container

Accessory

- Kit for connection to CMIS (Certus Management Information Systems) network. CMIS provides vital statistics, error codes, maintenance intervals, process receipt, etc.



CMIS can be fitted to washer extractors with Clarus Control, tumble dryers with Selecta Control and ironers with electronic control system. All you need to access and view the statistical feedback is a normal PC.