



Tumble dryer

T5675

Features and benefits

- Axial airflow and tight construction gives low energy consumption
- High productivity - 2 full loads per hour
- Large door opening for easy loading and unloading
- Easy and ergonomic access to the lint screen
- Excellent water evaporation efficiency per kWh
- The coin version with Ecopower to avoid over drying of the garments and get a lower energy consumption
- With Compass Pro program control
 - Large and clear display with control knob for easy program selection
 - Easy access with user-friendly interface
 - Language selection
 - Drying program packages optimized for Economy, Care and Time
 - Service program for adjustment of parameters
 - USB connection

Main options

- Stainless steel front
- Stainless steel drum
- Residual Moisture Control - RMC
- Connection to booking- /payment- system or coin meter
- Reversing drum
- Emergency stop button
- Supply disconnecter
- Frequency controlled motor

Accessories

- Fresh air intake
- Exhaust on top
- Insert for drying special equipment



Images shown are a representation of the product only and variations may occur.

Main specifications			T5675			
Rated capacity,	filling factor 1:18	kg/lb	37.5/82.7			
	filling factor 1:22	kg/lb	30.6/67.5			
Drum volume		litre	675			
Drum diameter		mm	913			
Heating alternatives						
	electric	kW	32/40			
	gas	BTU/h (kW)	14 3400 (42)			
	steam at 600-700 kPa	kW	46			
Consumption data*			32 kW	40 kW	Gas	Steam
Total time at 30.6 kg		min	28	23	23	22
Energy consumption at 30.6 kg		kWh	15.10	15.08	16.42	19.27
Evaporation		g/min	544	676	653	700
Energy kWh/litre water evaporated		kWh/l	0.98	0.98	1.07	1.26

* At rated capacity 100% cotton load at 50% initial moisture dried to 0%.



Electrical connections			T5675
Heating Voltage			
El.	380-415V 3/3N AC 50/60 Hz	kW(A)	34.6 (50)
	380-415V 3/3N AC 50/60 Hz	kW(A)	42.6 (63)
	440-480V 3AC 60 Hz	kW(A)	34.7 (50)
	440-480V 3AC 60 Hz	kW(A)	42.7 (63)
	230-240V 3AC 50/60 Hz	kW(A)	34.4 (100)
	230-240V 3AC 50/60 Hz	kW(A)	42.4 (125)
Gas/ steam	380-415V 3/3N AC 50/60 Hz	kW(A)	2.6 (10)
	440-480V 3AC 60 Hz	kW(A)	2.7 (10)
	230-240V 3AC 50/60 Hz	kW(A)	2.4 (10)
	230-240V 1AC 50/60 Hz	kW(A)	2.2 (10)
Steam, gas and air connections			
Steam	ISO 7/1-R		1"
Steam pressure		kPa	100-1000
Steam consumption		kg/h	65
Condensate	ISO 7/1-R		1"
Gas	NG/PG	ISO 7/1-R	1/2"
	Natural gas		2000
Gas pressure		mbar	20
	Propane		2800-3700
		mbar	28-37
Air outlet		ø mm	200
Maximum air flow:			
	Electric 50 Hz / 60 Hz	m ³ /h	1140 / 1140
	Gas 50 Hz / 60 Hz	m ³ /h	1140 / 1140
	Steam 50 Hz / 60 Hz	m ³ /h	1380 / 1380
Maximum static back pressure:			
	Electric 50 Hz / 60 Hz	Pa	270 / 800
	Gas 50 Hz / 60 Hz	Pa	410 / 800
	Steam 50 Hz / 60 Hz	Pa	900 / 1100
Sound levels			
Airborne sound levelB(A)			<70
Heat emission			
% of installed power, max			15
Shipping data (el/steam/gas)			
	net, kg		340
	crated, kg		375
	boxed, kg		515
Shipping volume	crated, m ³		3.57
Dimensions in mm			
A	Width		960
B(a)	Depth		1510
B(b)	Depth		1640
C	Height		1855
D			660
E			720
F			170
G			1490
H			200
I			180
J			1560
K			50
L			480
M			580
N			805
1	Control panel		
2	Door opening ø 810 mm		
3	Electrical connection		
4	Gas connection		
5	Exhaust connection		
6	Condensate connection		
7	Steam connection		
8	Lint screen		

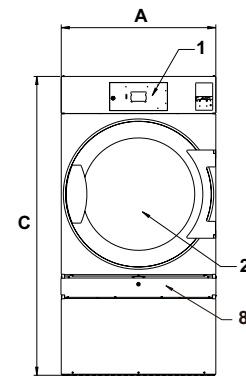

Front

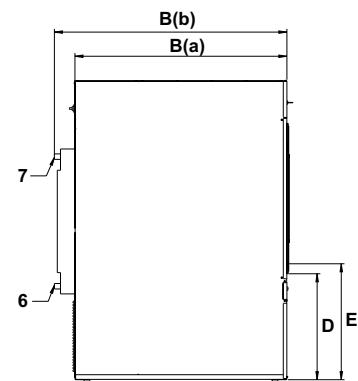

Left side

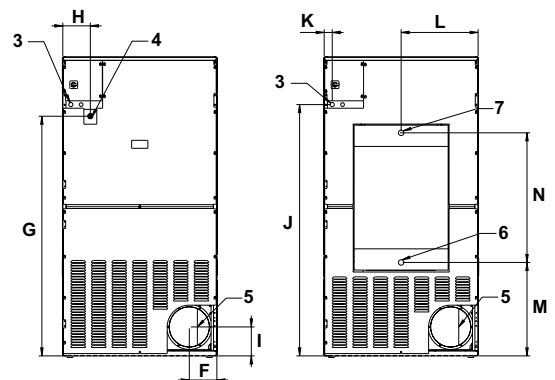

El, gas

Steam

Rear side

* Maximum consumed air when the machine is optimally installed.